

VINCENT HORIZONTAL PRESS

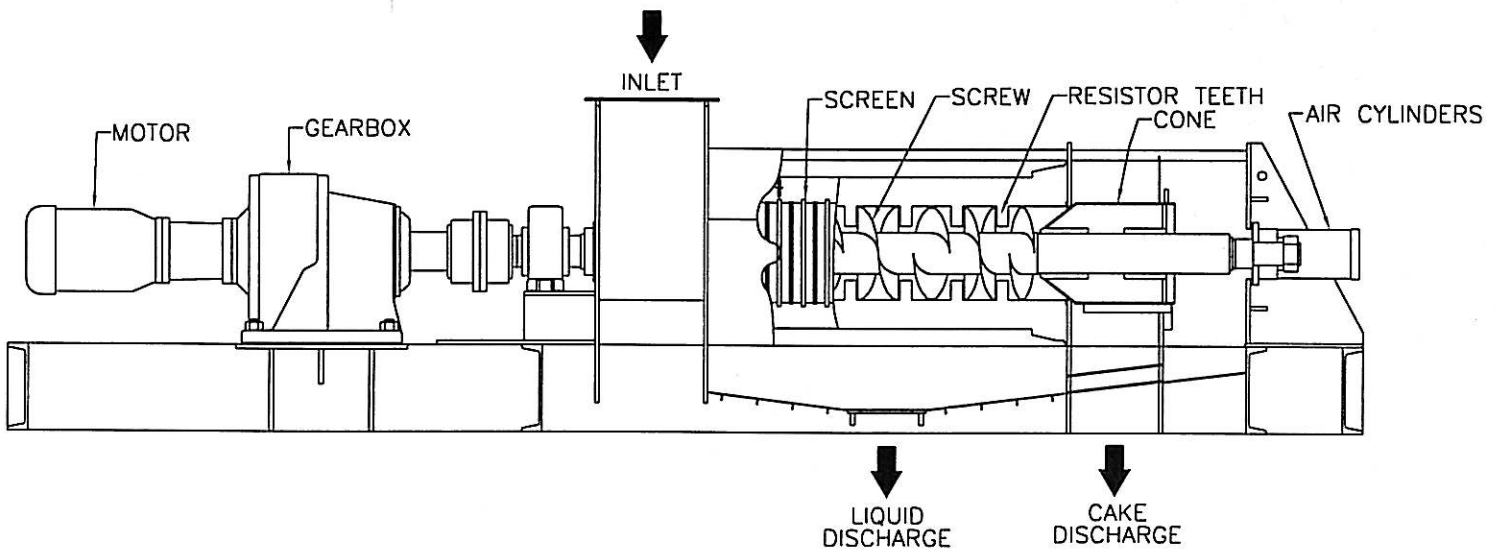

The Vincent Screw Press has proven successful in both virgin fiber and recycle mills. It has a graduated pitch and interrupted flight screw. Final pressing is controlled by a pneumatically actuated cone that adjusts solids content of the press cake. Profile bar

screens and hardsurfaced wear areas are standard. Excellent service is obtained on screen rejects, shives, knots, and clarifier sludge. Inbound consistencies of 2% to 20% solids or greater are accepted. Press cake is controllable in the range of 25% to 55% solids.

Model	Capacity *		Screw RPM	HP	Length FT	Width FT	Height FT	Weight LBS
	TPD, DS	GPM						
CP - 4	.5-1	6	27	1.5	3.5	1.2	1.5	500
CP - 6	2-4	20	26	5	7	1.5	2.5	1,000
CP - 10	5-10	70	16	15	9	2	3	3,000
CP - 12	10-20	150	14	25	13	2.5	4	8,000
VP - 16	20-45	300	13	30	19	4	5	12,000
VP - 24	40-100	600	9	60	24	5	6	28,000
VP - 30	60-150	1200	7	125	35	7	9	62,000

*SUBJECT TO ON-SITE TESTING. A LARGE RENTAL FLEET IS AVAILABLE FOR THIS PURPOSE.

Vincent
CORPORATION

